

# SME

PRECISION PICK-UP ARMS



*Models 3009-R,  
3010-R and 3012-R*

These precision pick-up arms embody well-tried SME features and are suited to a broad range of cartridges with special emphasis on those of medium and low compliance.

**Model 3009-R** is the standard arm having a typical pivot to stylus distance of 9-18" (233-2 mm) and will therefore be most frequently used. Average effective mass is 12-7 grams.

**Model 3010-R** is identical to Model 3009-R except that the pivot to stylus distance is -242" (6-15 mm) longer. It should only be selected for decks requiring the extra length. Average effective mass is 12-8 grams.

**Model 3012-R** has a typical pivot to stylus distance of 12-158" (308-8 mm) and therefore requires a large deck to accommodate it. Adaptation of decks designed for 9" (229 mm) arms is often possible provided the arm and turntable are rigidly coupled. It would not be satisfactory to mount the arm outboard on the fixed portion of a deck incorporating a floating sub-chassis. Distortion caused by lateral tracking error is at least 25% less than is possible with a 9" (229 mm) arm. Average effective mass is 14 grams.

The tone arm of highly polished stainless steel provides excellent rigidity although its wall thickness is only -010" (0-25 mm). A fibrous lining assists the dissipation of acoustic information.

The balance system is adjustable for cartridges weighing 1-5-26 grams or plug-in heads up to 33-5 grams. A transverse coupling allows movement in relation to the tone arm to achieve lateral balance.

The S2-R shell is pressed from heavy gauge aluminium alloy rationally perforated for lightness and strength, providing a solid platform for the attachment of the cartridge. The bayonet has double draw-in pins ensuring that it is held rigidly and does not tilt in the arm socket.

The 'R' models are easily adjustable and convenient where rapid interchange of cartridges is required. Their construction and effective mass allows smooth, uncoloured reproduction from cartridges requiring a vertical tracking force of 1-25 grams and upwards.

A fluid damper, FD 11-R, is an optional extra. The normal passage of the arm across the record is unaffected but influences which tend to produce over-rapid motion are resisted by the flow characteristic of the fluid, reducing sensitivity to shock. It is effective in both planes and can be adjusted to give different rates of damping.

#### Dimensions

	3009-R		3012-R	
	Inches	mm	Inches	mm
Nominal length, pivot to stylus	9-180	233-2	12-158	308-8
Distance from bedplate centre to turntable centre (L)	8-480	215-4	11-638	295-6
Tracking adjustment	±0-50	±12-7	±0-50	±12-7
Height above mounting surface (H) – adjustable				
max.	3-125	79-3	3-125	79-3
min.	2-375	60-3	2-375	60-3
Height of turntable surface above mounting surface (T)				
max.	1-625	41-3	1-625	41-3
min.	1-062	27-0	1-062	27-0

Note When the turntable surface is more than 1½" (41-3 mm) above the surface on which the arm is mounted, a spacer, SME accessory P1, is required.

Depth required below mounting surface (D)	1-875	47-6	1-875	47-6
Clearance required for balance weights (R)	2-750	69-9	3-250	82-5
Clearance required between turntable surface and cabinet lid (C)	1-750	44-5	1-750	44-5

	3010-R	
Nominal length, pivot to stylus	9-422	239-3
Distance from bedplate centre to turntable centre (L)	8-740	222-0

All other dimensions are as 3009-R.



Fluid Damper FD 11-R

- ★ Thin-walled stainless steel tone arm.
- ★ Low friction pivots. Vertical axis: high precision, fully protected ballraces. Horizontal axis: -005" radius knife-edges rolling in planished chrome seatings. Less than -02 gram applied at the stylus will deflect the arm.
- ★ Extra-rigid low mass shell with double draw-in pins.
- ★ Geometry optimised for 12" (30 cm) LPs.
- ★ Base slides on bedplate for tracking adjustment with double null-point protractor.
- ★ Balance system with longitudinal and lateral fine adjustment for cartridges weighing 1-5-26-0 grams or plug-in heads up to 33-5 grams.
- ★ Precise tracking force up to 5-0 grams applied without a tracking force gauge.
- ★ Fluid damped lowering and raising control.
- ★ 4 ft (1-22 M) audio lead with gold plated phono plugs (S3L4). Alternative 5-pole DIN termination (S3L4D) available on request.
- ★ Electrical contacts heavily gold plated.

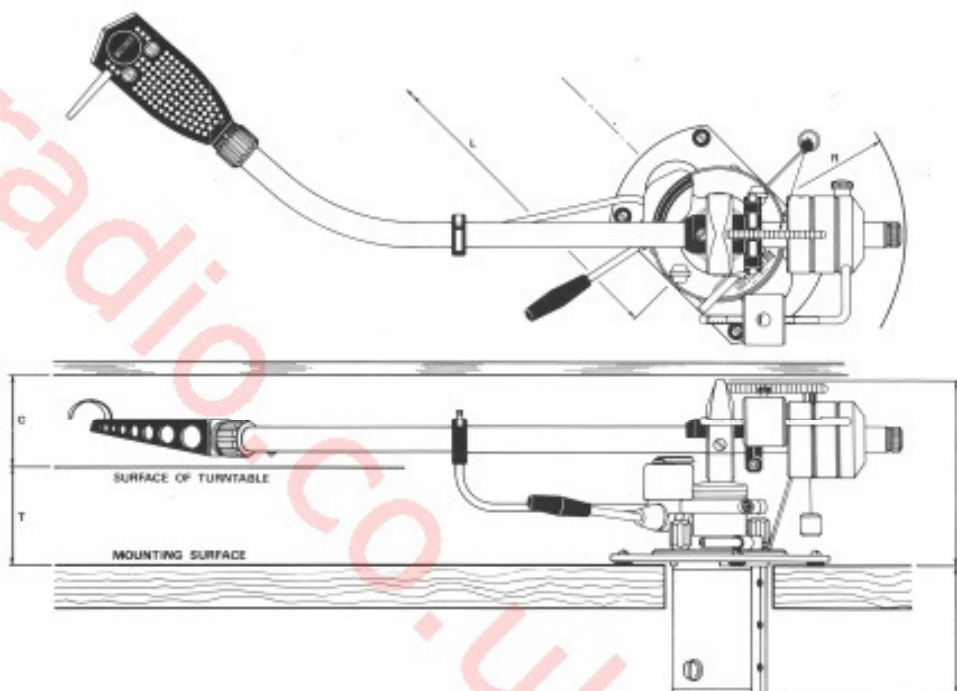

# SME

Manufactured by

SME LIMITED · STEYNING · SUSSEX · BN4 3GY · ENGLAND · ☎ STEYNING (09903) 814321 · TELEX 877808 SME G