

INSTRUCTION BOOK

**QUAD  
MULTIPLEX  
DECODER**



www.valve-radio.co.uk



THE ACOUSTICAL MANUFACTURING CO., LTD.  
HUNTINGDON HUNTS. ENGLAND  
TELEPHONE : 2561/2 TELEGRAMS : ACOUSTICAL HUNTINGDON

## **THE PILOT TONE SYSTEM OF STEREOPHONIC BROADCASTING**

The pilot tone (otherwise known as the Zenith - GE) system of stereophonic broadcasting allows any VHF - FM tuner to receive a mono version of the programme which is the addition of the original left and right hand channels.

The stereo information is the difference between the left and right hand channels. This has to be recovered separately from the sum signal and it is transmitted as a signal above the limits of audibility. The listener with a mono receiver is therefore not aware of the stereo information.

The purpose of the multiplex decoder is to translate these inaudible difference signals and to combine them with the sum signal in such a way that the original left and right hand channels re-appear separately.

## **THE QUAD MULTIPLEX DECODER**

The QUAD multiplex decoder is designed specifically for use with the QUAD FM tuner and QUAD 22 control unit.

Its internal mono-stereo electronic switching is operated remotely from the QUAD 22 controls. It may, therefore, be concealed within the equipment cabinet without any need for access after installation.

## INSTALLATION

### Preparing the FM Tuner

If the Serial No. of the Quad FM tuner is above 19062 a switch is fitted near V6 (see fig. 1). When used with the Multiplex Decoder the switch should be moved to the stereo position, marked RED.

If the Serial No. of the Quad FM tuner is less than 19062 the tuner should be modified as follows:—

- (1) Disconnect capacitor C33 ( $.04\mu$ ) from pin 5 of valve V6 (6AL5). If this component is left in position the lead wire should be placed so that accidental contact cannot be made with any other part of the circuit. Replace C32 (47p) by a capacitor of 15p.
- (2) Remove the Brown audio lead from the pillar tag at the junction of resistors R20 (220K), R21 (100K) and capacitor C34 (1000p).

- (3) Connect the Brown audio lead via a 2.2K resistor (Dubilier BTT or equivalent) to pin 5 of valve V6 (6AL5). Keep the resistor close to pin 5 (see fig 2).

### Connections between units

The FM tuner — Multiplex Decoder — Quad 22 control unit connections are shown in fig. 3.

The Multiplex Decoder may be fitted on the rear of the Quad FM tuner cover by removing the tuner cover fixing screws and replacing them through the holes in the sliding bracket under the decoder cover (see fig. 4).

The optimum performance for the decoder will be obtained in moderate temperature. If the cabinet ventilation is such that the air in the FM tuner compartment exceeds  $40^{\circ}\text{C}$  ( $104^{\circ}\text{F}$ ) the decoder should be moved from the tuner cover and placed in a cooler part of the cabinet, e.g. near an air intake on the cabinet floor.

QUAD F.M. TUNER ABOVE SER.No. 19062.

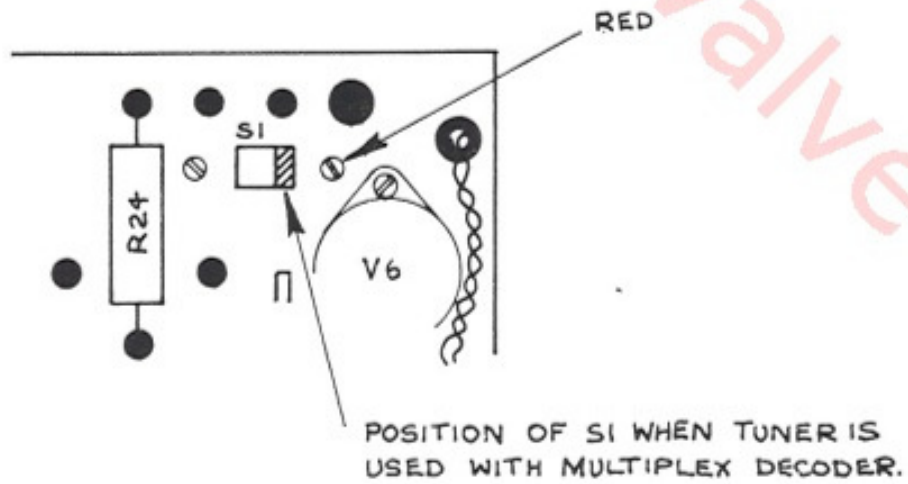

FIG 1.

QUAD F.M. TUNER BELOW SER.No.19062

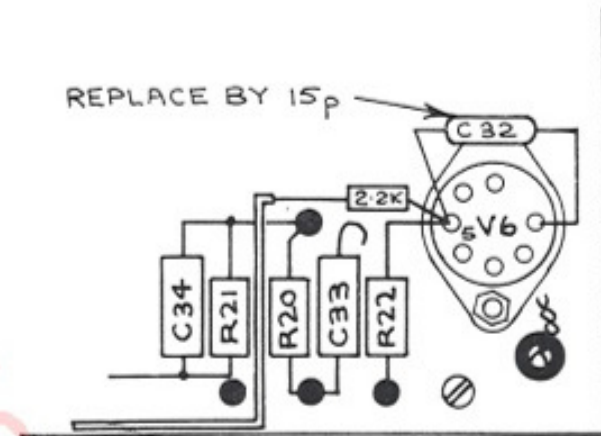

FIG 2.

WWW.LOVE-RADIO.CO.UK

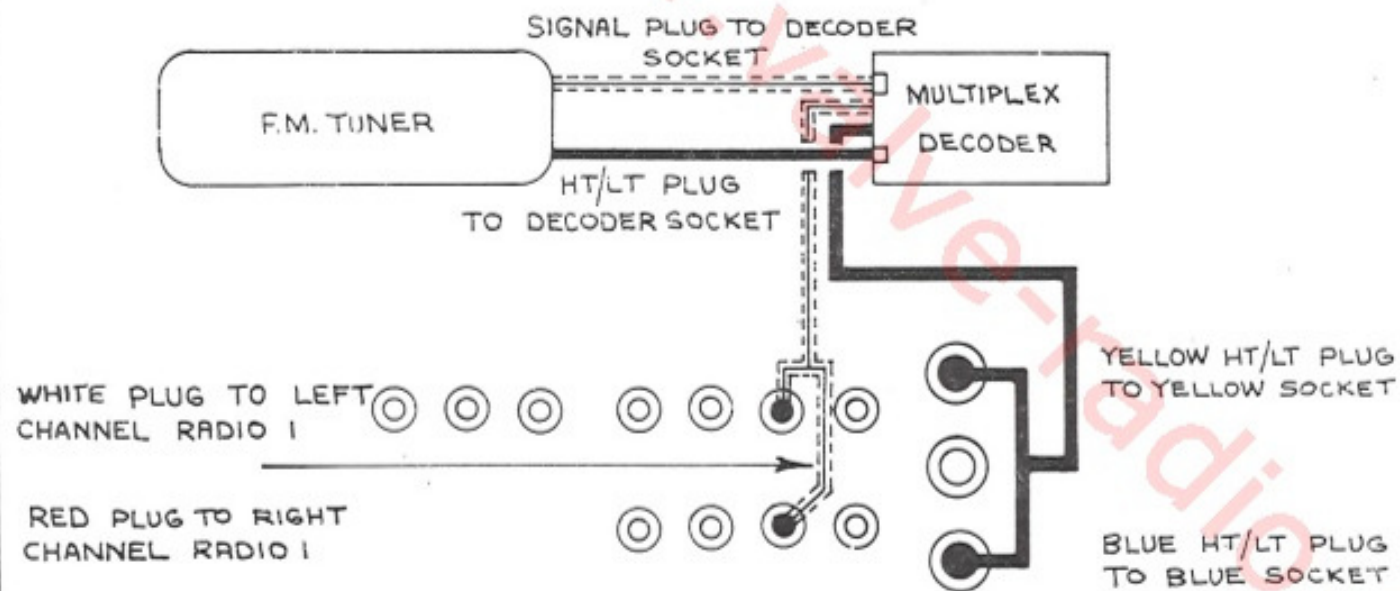

FIG. 3

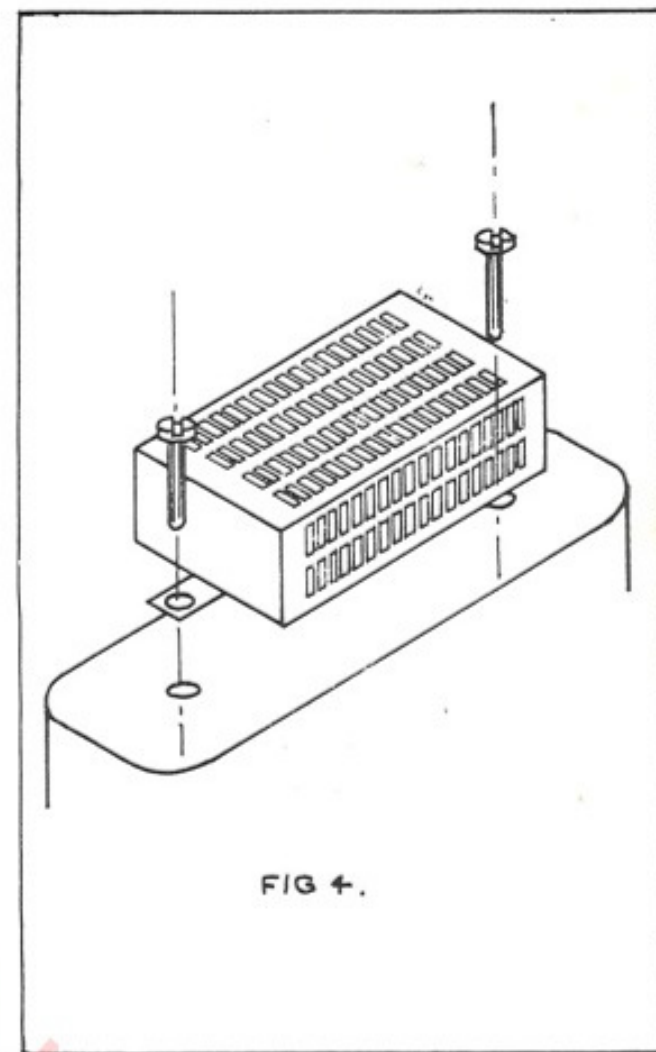

FIG 4.

## OPERATION

### Mono

Press RADIO and MON or 2-MON push-buttons. All transmissions will be heard from the tuner in the normal way. Stereo broadcasts will be heard in their mono form, i.e. left and righthand channels added together.

### Stereo

Press RADIO and STEREO pushbuttons. After the Blue channel power amplifier has warmed up mono transmissions and interstation noise will be muted and only stereo transmissions will be heard. If no signals are audible when tuning through the VHF band then there are no stereo broadcasts being transmitted within range at that time.

### Long Distance Reception

Fading and background noise are more apparent when receiving stereo transmissions from distant stations. The stereo information is degraded more than the mono channel so that fading and background noise, if obtrusive, may be reduced by reverting to Mono reception.

## SPECIFICATION

### De-emphasis:

50 $\mu$ S (European standards)  
75 $\mu$ S (North American standards)

### Output voltage:

100mV (Nominal for 30% modulation)  
into 100K ohms

### Crosstalk:

Better than 30 dB at 1 kc/s

### Suppression:

19 kc/s Pilot tone better than 36 dB  
38 kc/s Switching tone better than 40 dB

### Power requirement:

330V DC, 8mA mono (from Yellow channel HT) plus 9mA stereo (from Blue channel HT)

## CIRCUIT DESCRIPTION

The detector output of the FM tuner (with the de-emphasis and attenuator circuits removed) is fed to the high impedance input stage (2G344) of the decoder. The low impedance emitter output of this stage drives a diode ring demodulator (4 x 1S44) via a 55Kc/s low-pass filter to remove any 67Kc/s sub-carrier signals present. The values of the low-pass filter are also chosen to effect overall phase compensation of the composite signal.

The diode ring demodulator is switched by the balanced output of a 38Kc/s oscillator (2G382). The left and right hand channels are recovered directly, but as harmonics of the difference signal sub-carrier are removed during transmission the difference signal is reduced to  $2/\pi$  times the sum signal. The equality of the sum and difference signals is restored by subtracting  $1-2/\pi$  times the sum signal from each channel, the necessary reversed phase signal being taken from the input stage collector circuit.

A tuned circuit in the input stage collector feeds the 19Kc/s pilot tone to the pilot tone amplifier (OC81). The push-pull output of this stage is rectified (2 x 1S920) in order to bias the diode signal switches (4 x 1S44) to the "Stereo On" position. The 38Kc/s rectifier current pulses are used to synchronise the locally generated 38Kc/s switching signal with the pilot tone.

The main supply voltage, stabilised by Zener diodes (2 x 1S2075), is supplied from the control unit when the RADIO button is pressed. This supply also biases the diode signal switches to MONO. If the STEREO button on the control unit is pressed the "Blue HT" supply switches the mono signal off, and the pilot tone amplifier on. If a pilot tone is present the decoder is thus switched to produce a stereo output.



## ALIGNMENT PROCEDURE

### Notes:

Each unit is fully aligned at the factory before despatch and alignment should not be required on installation. Should subsequent re-alignment become necessary the following procedure should be followed.

The decoder must be aligned with the printed board securely in position inside its cover. Access to the unit is through the cover holes.

The 67 Kc/s adjustment given in paragraph (2) must be correct even if no 67 Kc/s sub-carrier is present in local transmissions. The meter used must respond to 67 Kc/s.

The 19 Kc/s pilot tone must be accurate in frequency ( $\pm 2$  c/s) and modulation level (8-10%) from the signal generator. The modulation level of the left or right tones (400-1000 c/s) should be 20-30%.

The FM tuner should be exactly in tune during alignment.

- (1) Connect the decoder to a Quad 22 and two power amplifiers in the normal way but leave the FM tuner signal and HT/LT leads disconnected. Switch the Quad 22 to STEREO-RADIO and run for 30 minutes to allow the decoder to reach operating temperature.
- (2) Switch Quad 22 to 2-MON-RADIO. Apply an accurate 67 Kc/s signal of between 1 and 3 volts to the decoder input.
- (3) Short-circuit L2 pin 1 to chassis. Connect AC meter (10mV full-scale) to either decoder output. Adjust L3 for minimum output. Remove L2 short-circuit.
- (3) Switch Quad 22 off. Connect Quad FM tuner to decoder. Switch Quad 22 to STEREO-RADIO. Tune carefully to signal generator modulated by 19 Kc/s pilot. Detune L4, adjust L1 then L4 for maximum DC (10-15V) across R9.

- (4) Short-circuit R10. Modulate signal generator with tone on one channel only. Listen to both loudspeakers and adjust L2 until tone swings slowly from one loudspeaker to the other. Remove short-circuit from R10.
- (5) Modulate signal generator with left-hand tone. Switch Quad 22 filter to 25 at 10 Kc/s. Connect AC meter across left-hand power amplifier output, set volume control to give 1 to 5 volts output. Adjust L4 slightly for maximum output.
- (6) Transfer meter to right hand amplifier output and adjust RV1 for minimum output (about 35db below left-hand).
- (7) Modulate signal generator with right-hand tone. Check that right-hand output is at maximum and left-hand output at minimum.

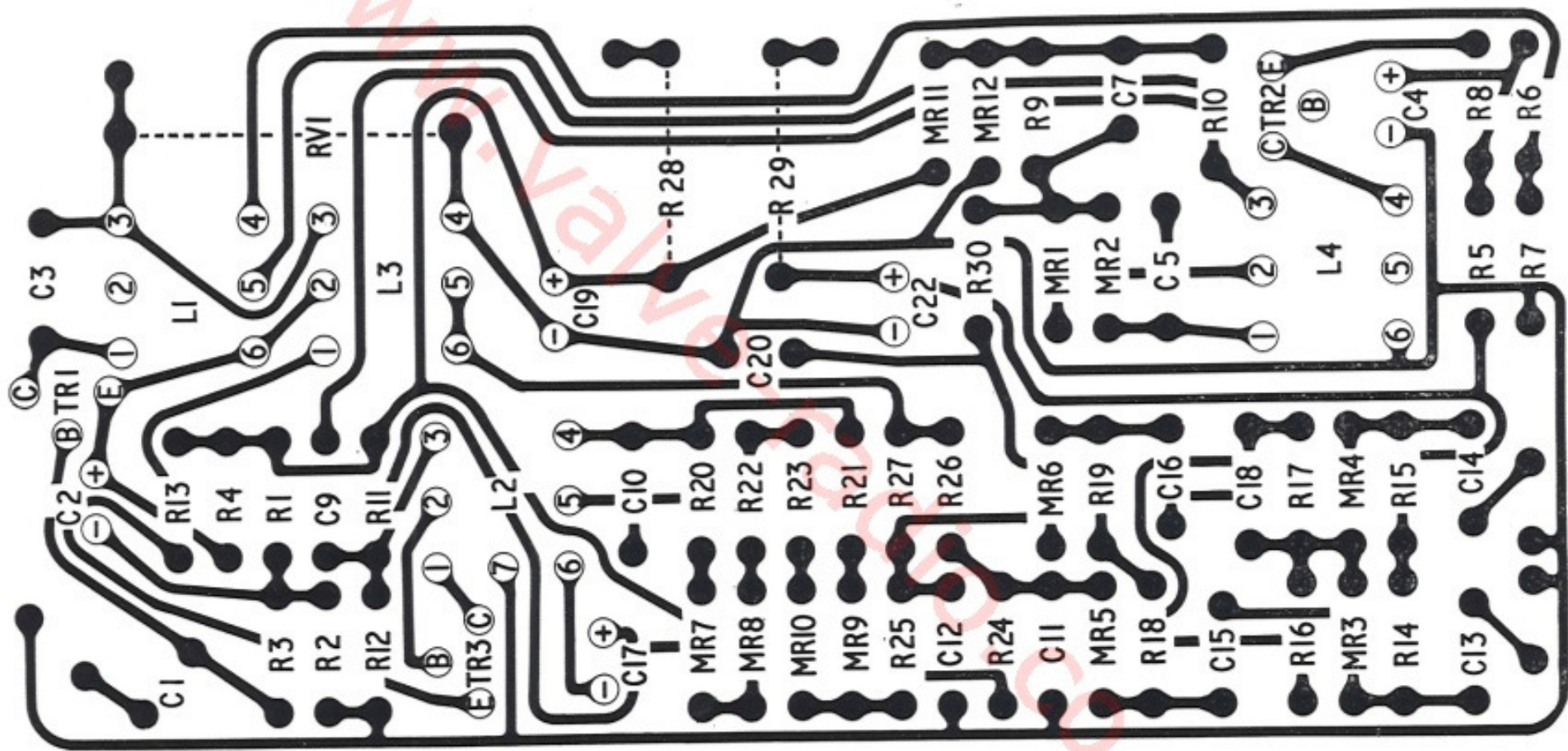

QUAD MULTIPLEX DECODER — COMPONENT LAYOUT UNDERSIDE

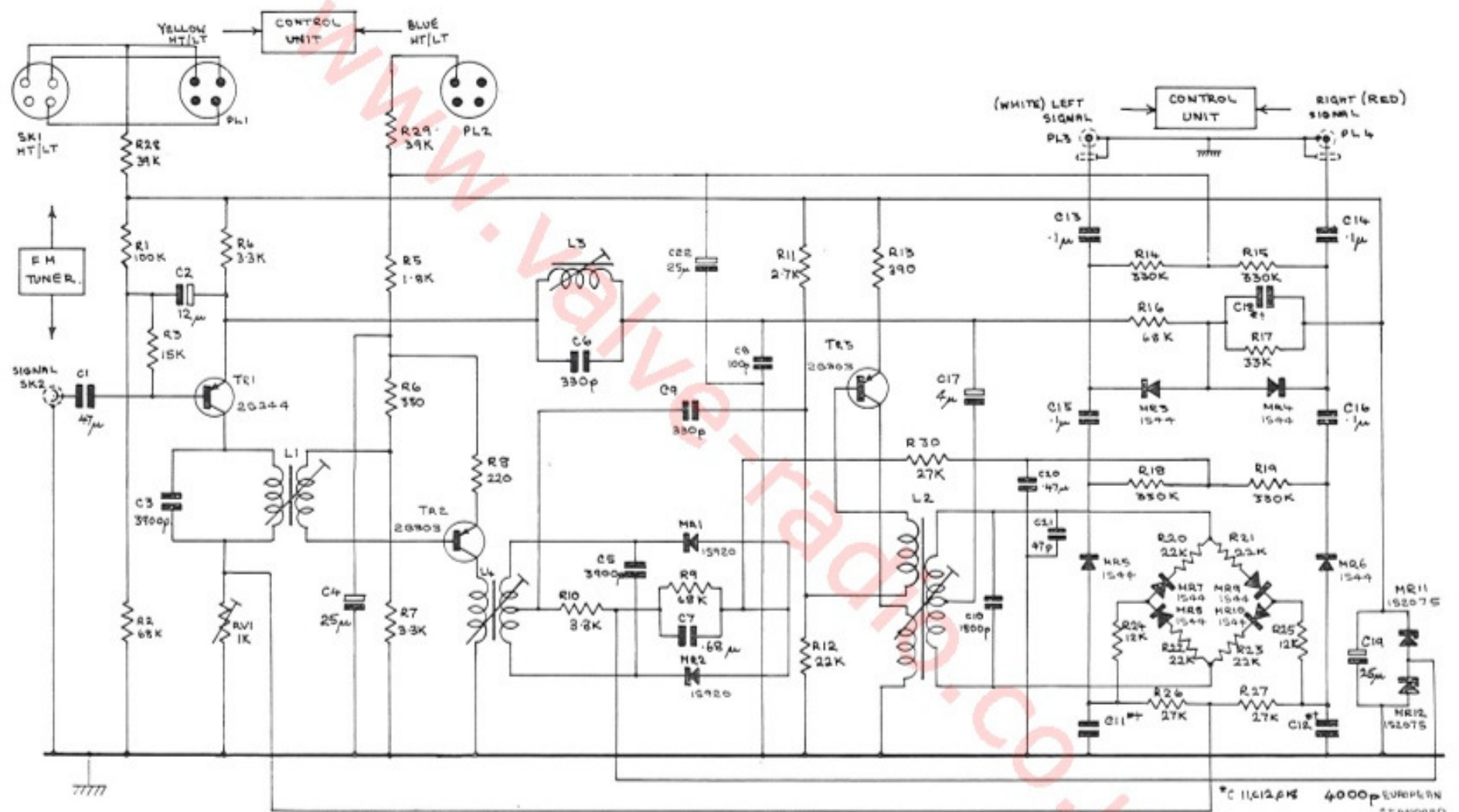

QUAD MULTIPLEX DECODER CIRCUIT DIAGRAM

## MULTIPLEX DECODER COMPONENTS LIST

Component Reference	Value	Tolerance	Maker's Reference	Stock No.
R1	100K	± 10%	Dubilier BTT	200/A
R2	68K	± 10%	Dubilier BTT	205/B
R3	15K	± 10%	Dubilier BTT	224/C
R4	3.3K	± 10%	Dubilier BTT	244/B
R5	1.8K	± 10%	Dubilier BTT	253/A
R6	330	± 10%	Dubilier BTT	280/C
R7	3.3K	± 10%	Dubilier BTT	244/B
R8	220	± 10%	Dubilier BTT	285/A
R9	68K	± 10%	Dubilier BTT	205/B
R10	3.3K	± 10%	Dubilier BTT	244/B
R11	2.7K	± 10%	Dubilier BTT	248/D
R12	22K	± 10%	Dubilier BTT	217/A
R13	390	± 10%	Dubilier BTT	275/A
R14	330K	± 10%	Dubilier BTT	179/B
R15	330K	± 10%	Dubilier BTT	179/B
R16	68K	± 10%	Dubilier BTT	205/B
R17	33K	± 10%	Dubilier BTT	209/D
R18	330K	± 10%	Dubilier BTT	179/B
R19	330K	± 10%	Dubilier BTT	179/B
R20	22K	± 7% TE	Welwyn F20	217/D
R21	22K	± 7% TE	Welwyn F20	217/D
R22	22K	± 7% TE	Welwyn F20	217/D

Component Reference	Value	Tolerance	Maker's Reference	Stock No.
R23	22K	± 7% TE	Welwyn F20	217/D
R24	12K	± 7% TE	Welwyn F20	228/E
R25	12K	± 7% TE	Welwyn F20	228/E
R26	27K	± 7% TE	Welwyn F20	210/E
R27	27K	± 7% TE	Welwyn F20	210/E
R28	39K	± 5%	Welwyn F75	208/N
R29	39K	± 5%	Welwyn F75	208/N
R30	27K	± 10%	Dubilier BTT	210/D
RV1	1K	± 10%	Egen 195	370/B
C1	.47 $\mu$	± 20%	TCC Metamold M.974/9	492/A
C2	12 $\mu$	—	TCC E.1072/9	472/B
C3	3900p	± 5%	Salford PF 125V	513/N
C4	25 $\mu$	—	TCC 25V E.1072/7	465/G
C5	3900p	± 5%	Salford PF 125V	513/N
C6	330p	± 5%	Salford PF 125V (Part of L3)	523/B
C7	.68 $\mu$	± 20%	TCC Metamold M.974/12	488/A
C8	100p	± 5%	Salford PF (Part of L3)	528/A
C9	330p	± 10%	Salford PF 125V	523/B
C10	1800p	± 5%	Salford PF 125V	515/H
C11*	4000p	± 10%	Hunts BD11A	513/E
C12*	4000p	± 10%	Hunts BD11A	513/E
C11†	5600p	± 10%	Hunts BD72A	509/B
C12†	5600p	± 10%	Hunts BD72A	509/B
C13	.1 $\mu$	± 20%	TCC PMX 4	495/F
C14	.1 $\mu$	± 20%	TCC PMX 4	495/F
C15	.1 $\mu$	± 20%	TCC PMX 4	495/F

\* European Standards

† North American Standards

Component Reference	Value	Tolerance	Maker's Reference	Stock No.
C16	.1 $\mu$	$\pm 20\%$	TCC PMX 4	495/F
C17	4 $\mu$	—	TCC 50V E.1072/8	482/A
C18*	4000p	$\pm 10\%$	Hunts BD11A	513/E
C18†	5600p	$\pm 10\%$	Hunts BD72A	509/B
C19	25 $\mu$	—	TCC 25V E.1072/7	465/G
C20	.47 $\mu$	$\pm 20\%$	TCC Metamold M.974/9	492/A
C21	47p	$\pm 5\%$	Salford PF (Part of L2)	534/A
C22	25 $\mu$	—	TCC E1071/6	465/H
TR1			Texas Instruments 2G344	
TR2			Mullard OC81	
TR3			Texas Instruments 2G382	
MR1			Texas Instruments 1S920	
MR2			Texas Instruments 1S920	
MR3			Texas Instruments 1S44	
MR4			Texas Instruments 1S44	
MR5			Texas Instruments 1S44	
MR6			Texas Instruments 1S44	
MR7			Texas Instruments 1S44	
MR8			Texas Instruments 1S44	
MR9			Texas Instruments 1S44	
MR10			Texas Instruments 1S44	
MR11			Texas Instruments 1S2075	
MR12			Texas Instruments 1S2075	
L1			Acoustical Drg A11697 Issue 4	750/A
L2			Acoustical Drg A11698 Issue 5	750/B
L3			Acoustical Drg A11699 Issue 3	750/C
L4			Acoustical Drg A11700 Issue 4	750/D

\* European Standards

† North American Standards